

Automatic forecast of water demand and availability based on meteo data

Prediction of water shortage in Switzerland

Graduate Candidates



Colin Eckert



Silas Hauser

Introduction: Climate change is one of today's most polarizing topics. The consequence of this phenomenon concerns people all over planet Earth. Water demand, caused by extreme weather conditions, is becoming an increasing problem. Even in Switzerland, which is usually well known for its balanced weather conditions, the consequences are more and more noticeable. Rittmeyer AG, the industry partner of this bachelor thesis, is one of the leading companies in the field of control engineering for water supplies in cities. The final goal for this thesis was to predict water demand and availability in Switzerland's cities to early recognize if there is a risk of shortage of water supply within sight.

Approach: For this thesis, multiple situations of water supply and their corresponding data were evaluated. While water related parameters were directly provided by Rittmeyer AG, additional weather data were sourced by the federal office for meteorology and climatology. After prescinding the water supply systems, water availability and consumption were the most important parameters to forecast a water shortage. After evaluating multiple meteo and water parameters in the past two years, their behavior was clearly non-linear. Hence polynomial regression models with quadratic and cubic algorithms were implemented and used in a final prediction model.

Result: As a result of this thesis, multiple functionalities were implemented which can be used within a GUI. It is possible to plot historical parameter data and evaluate their correlations. With the help of forward selection, the parameters temperature, rain, and sun were defined as most valued predictors. Mul-

multiple quadratic and cubic models were implemented, trained and tested. With the final model, it is possible to predict the water availability with an accuracy of approximately 10% and the water demand with 5%. With the help of current weather forecasts, provided by an API, it is possible to predict a trend for the next seven days.

Hydraulic situation of a water supply.

Rittmeyer AG

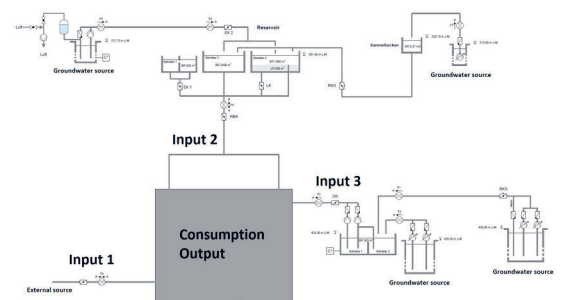

Prediction of consumption in May 2020 with an accuracy of approximately 5%.

Own presentment

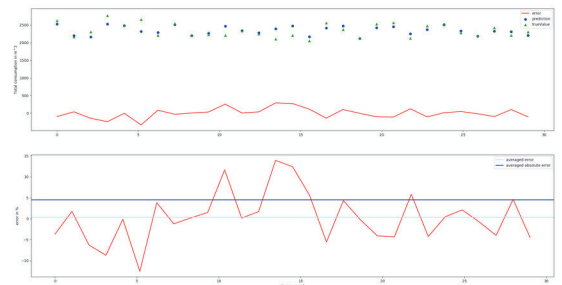

General overview of a station. The light blue colored period represents the predictions.

Own presentment

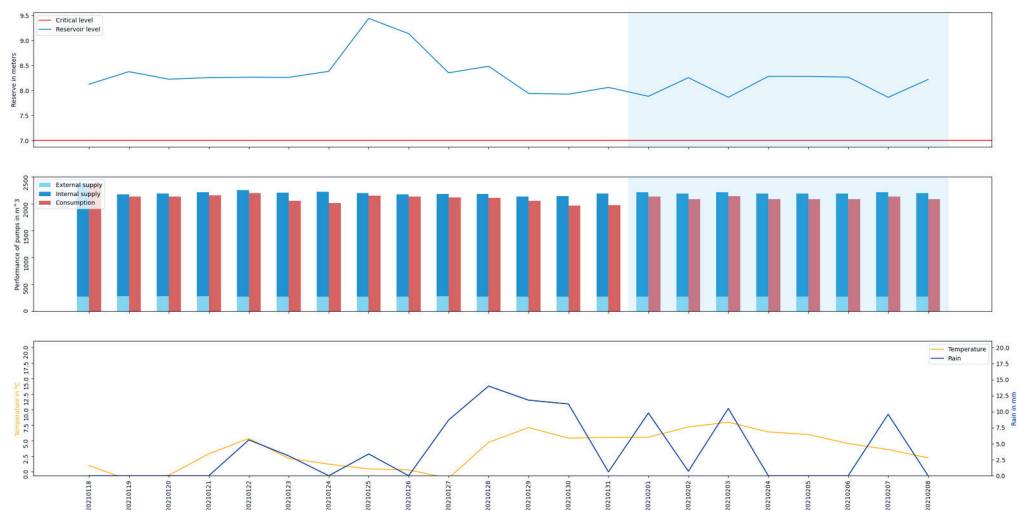

Advisor

Hannes Badertscher

Co-Examiner

Gabriel Sidler, Teamup Solutions AG, Zürich, ZH

Subject Area

Artificial Intelligence

Project Partner

Rittmeyer AG, Baar, ZG