



# CO<sub>2</sub> High-Temperature Heat Pump for Vegan Cheese & Dairy Alternatives

Cordin Arpagaus<sup>1</sup>, Frédéric Bless<sup>1</sup>, Stefan S. Bertsch<sup>1</sup>, Christian Maibach<sup>2</sup>

<sup>1</sup> OST Ostschweizer Fachhochschule, Institut für Energiesysteme (IES), 9471 Buchs, [cordin.arpagaus@ost.ch](mailto:cordin.arpagaus@ost.ch)

<sup>2</sup> New Roots AG, 3672 Oberdiessbach, [www.newroots.ch](http://www.newroots.ch)

CO<sub>2</sub>-HTWP supplier: Enx (IT), Type: E4/B Installation/operation: Zaugg AG, Thun In operation since March 2021



## Goals and Motivation

New Roots AG, a vegan dairy producer in Oberdiessbach (Emmental, Switzerland), manufactures plant-based cheese and dairy alternatives from nuts and other raw materials.

While product maturation and storage require cooling, pasteurization, fermentation, and cleaning processes demand significant process heat, making the system well-suited for an HTHP.

The aim was to reduce CO<sub>2</sub> emissions by a factor of ten compared to traditional cheese production through targeted heat recovery (waste heat utilization), thermal storage, and intelligent energy management [1, 2, 3].

## Energy System and HTHP Cycle Design

At the core of the energy system is an HTHP using CO<sub>2</sub> (R744) as the refrigerant (Figure 1), delivering both heating and cooling without fossil fuels.

A 40,000-liter stratified water storage tank provides thermal storage and enables targeted energy control (Figure 2), while surplus heat is discharged into the groundwater [2].

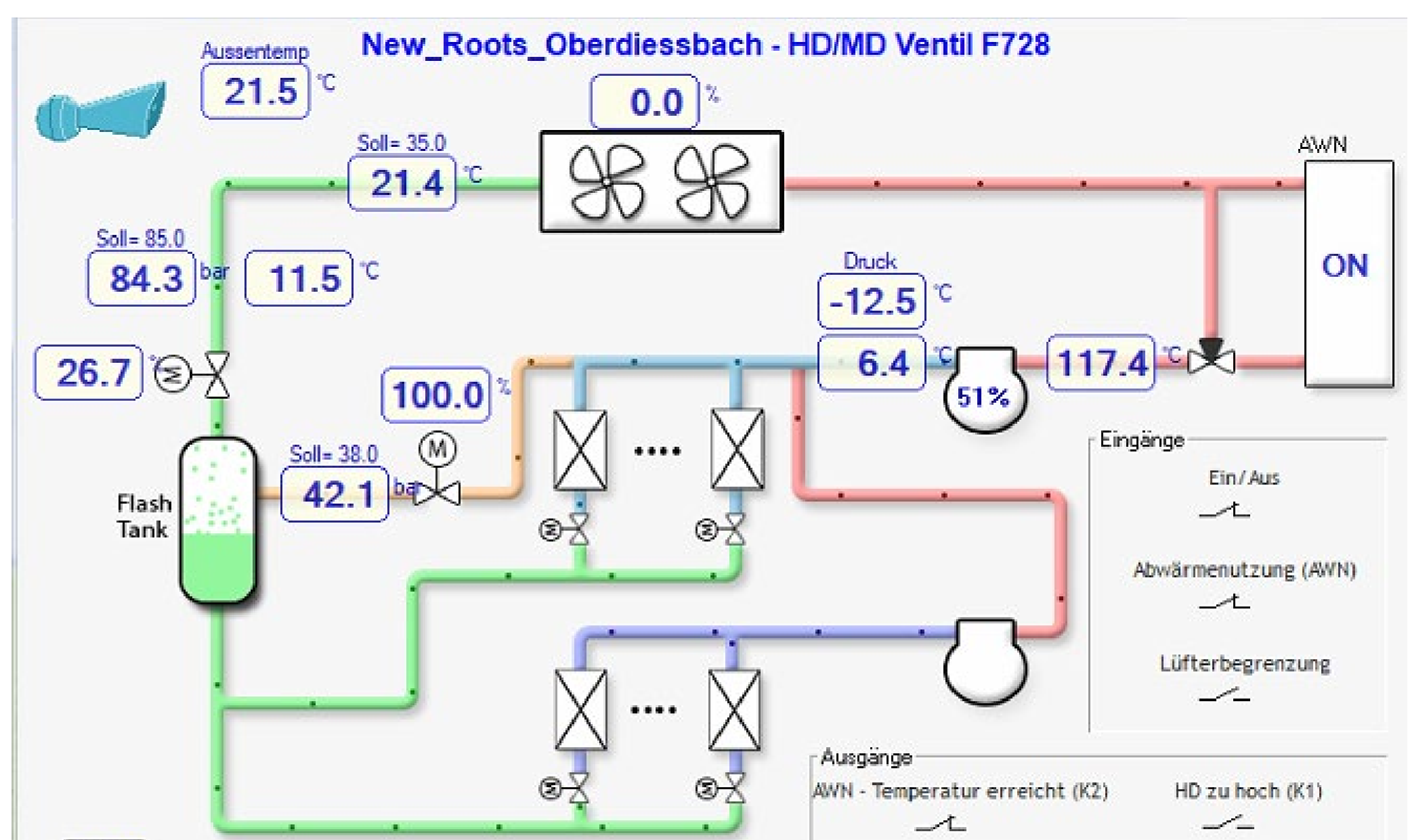

Figure 1: Schematic of the CO<sub>2</sub>-HTHP at New Roots AG.

## Funding

SwissEnergy, the SFOE's program for energy efficiency and renewable energies, provided financial support for New Roots AG's heating and cooling installation [1].

## 40,000-liter Stratified Storage Tank

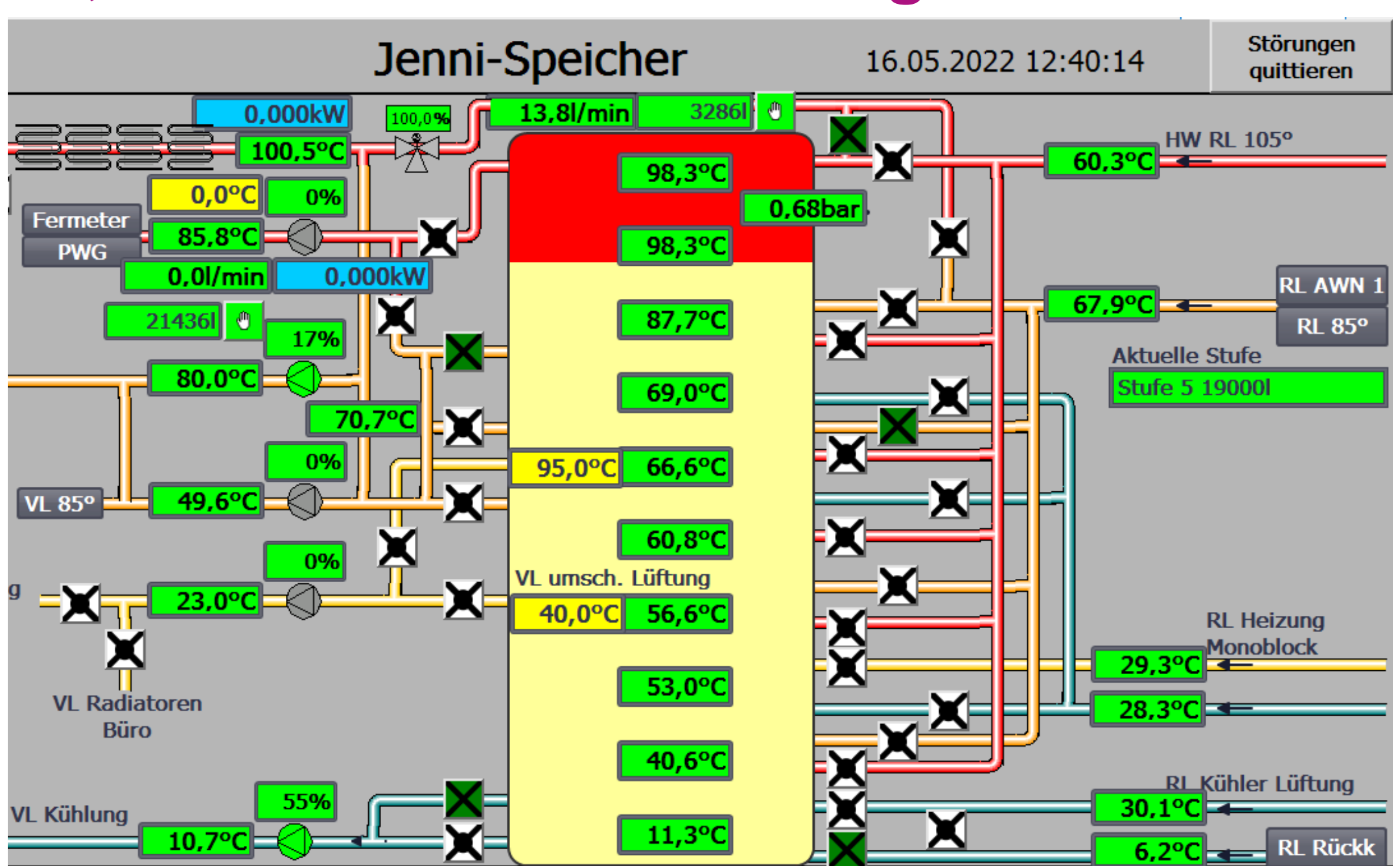

Figure 2: 40,000-liter stratified storage tank with 8 outlets and 22 inlets at different heights (steel tank, 7.5 x 2.7 m, H x W). The temperature ranges between 15 and 105 °C can be continuously monitored and controlled [1] (News Roots AG [2], AWN = Abwärmenutzung (heat recovery)).

## Results of fossil-free cooling and heating

CO <sub>2</sub> -High-Temperature Heat Pump (transcritical)	
CO <sub>2</sub> hot gas cooling (85 → 105 °C)	23 kW
CO <sub>2</sub> warm gas cooling (20 → 65 °C)	125 kW
CO <sub>2</sub> Evaporation (10 °C)	90 kW
Coefficient of performance for heat (COP)	1.93
Energy efficiency ratio for cooling (EER)	2.34
Stratified storage tank (40,000 liters of water)	
AWN2 (37%; 155,000 Liters/month)	68 → 98 °C
AWN1 (63%; 250,000 Liters/month)	20 → 60 °C

The CO<sub>2</sub>-HTHP runs smoothly and reliably [1], supplying the cold rooms with the necessary cooling water while also serving the thermal storage system. Its management works well, and the stratification in the storage tank is stable [1].

## References

- [1] EnergieSchweiz: CO<sub>2</sub>-freundliche Produktion veganer Alternativen zu Käse, <https://www.energieschweiz.ch/stories/waermepumpe-lebensmittelherstellung>
- [2] BFE-Magazin energieplus (5.10.2023): Wie vegane Alternativen von Käse energie- und klimafreundlich produziert werden, <https://energieplus.com/2023/10/05/wie-vegane-alternativen-von-kaese-energie-und-klimafreundlich-produziert-wird>
- [3] Arpagaus, C., Bless, F., Bertsch, S.S., Maibach, Ch.: CO<sub>2</sub>-Hochtemperatur-Wärmepumpe (HTWP) in der Produktion von veganen Alternativen zu Käse und Milchprodukte (Poster), 30. Tagung des BFE-Forschungsprogramms «Wärmepumpen und Kältetechnik», 26. Juni 2024, Eventfabrik, Bern, [https://www.fws.ch/wp-content/uploads/2024/10/Bericht\\_Waermepumpentagung\\_Bern\\_2024\\_UG\\_und\\_Inhalt\\_low.pdf](https://www.fws.ch/wp-content/uploads/2024/10/Bericht_Waermepumpentagung_Bern_2024_UG_und_Inhalt_low.pdf)