



Steam Cogeneration Heat Pumps for the Food, Dairy and Meat Industries

Tim Walmsley*, Ben Ong, Keegan Hall, Ben Lincoln, Florian Schlosser, Jasper Walden, Roger Padullés, Duy Hoang, Michael Walmsley, Cordin Arpagaus

*Presenter from
School of Engineering, University of Waikato, New Zealand

Overview

- Background
- Pinch Analysis
- Principles of Heat Pump Integration
- Case Studies
- Patterns of Heat Pump Integration
- Conclusions

Goal:

How can we **integrate industrial heat pumps** into sites at **minimum lifetime cost**?

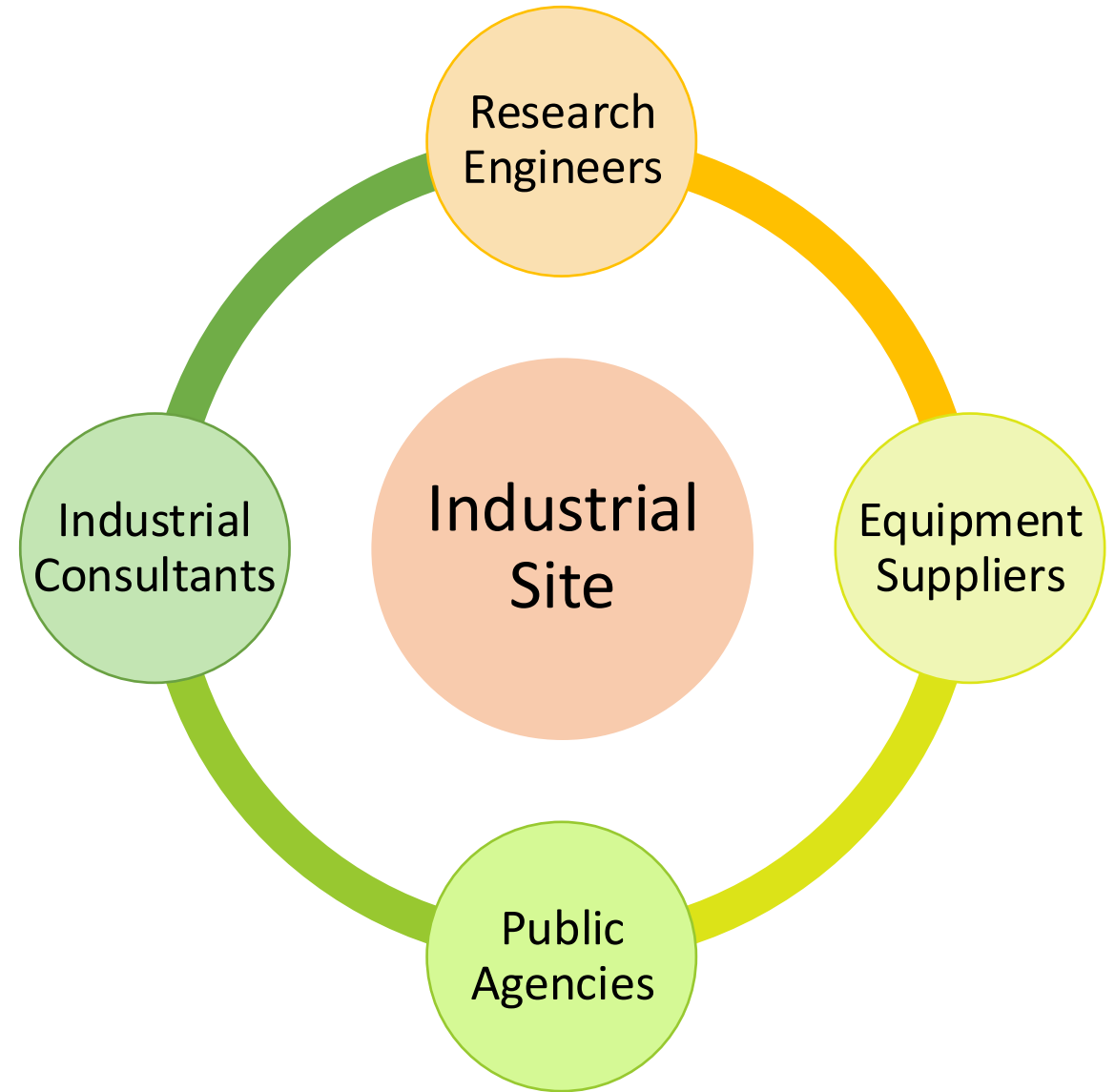

Industrial Site: Typical Structure

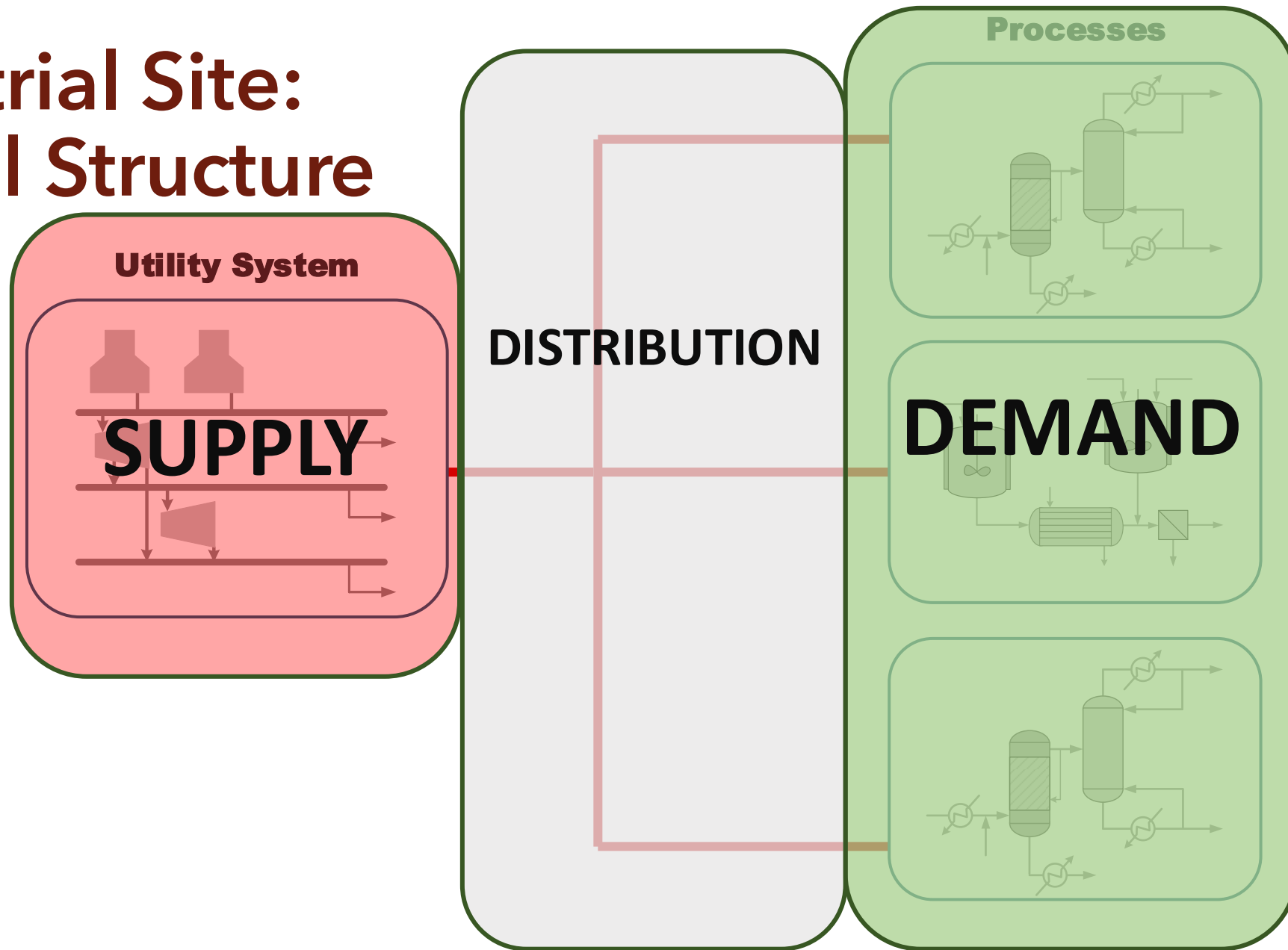

Central or Local or Other?

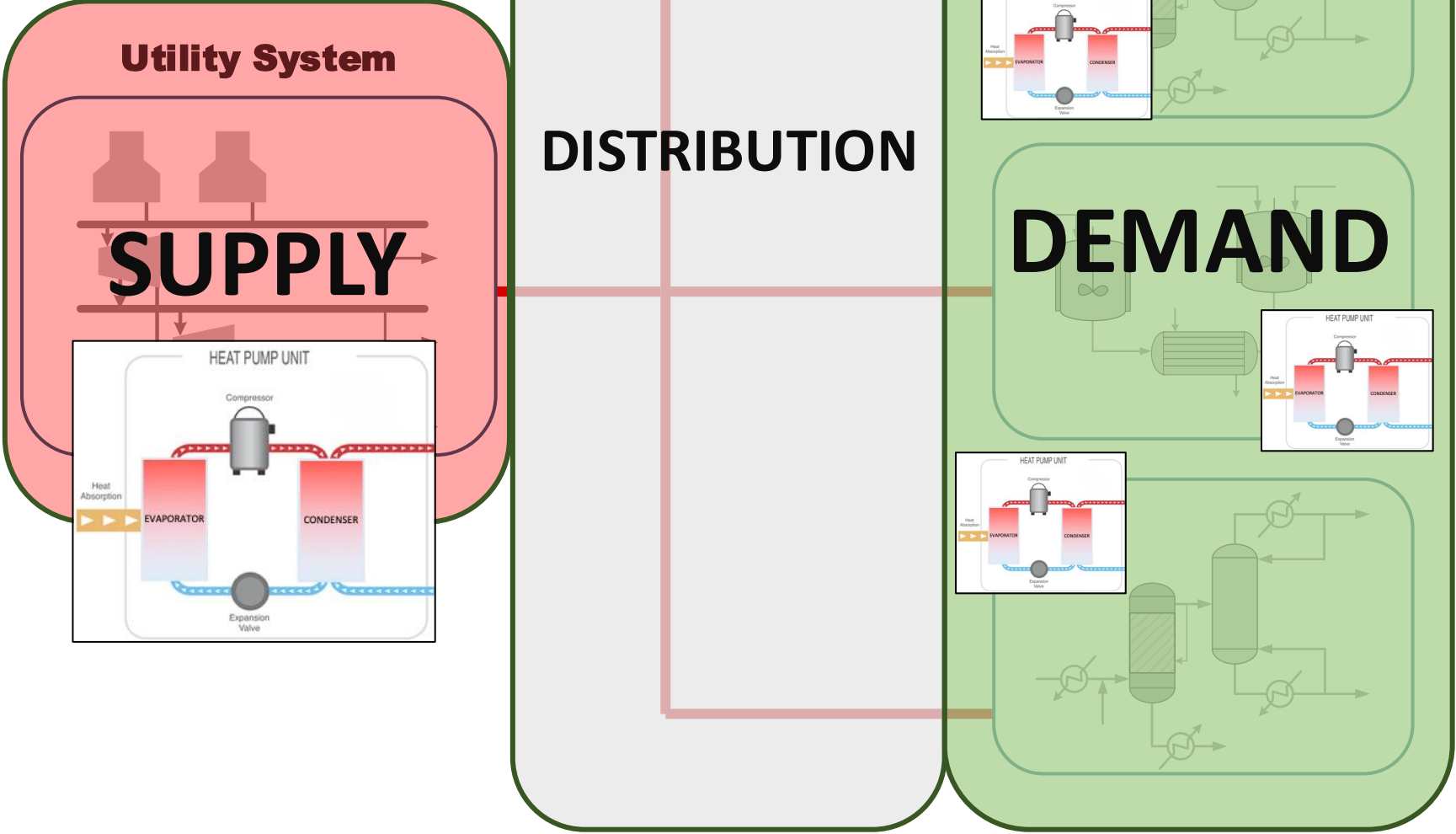

A Pinch Analysis Perspective

a) Abstract principle

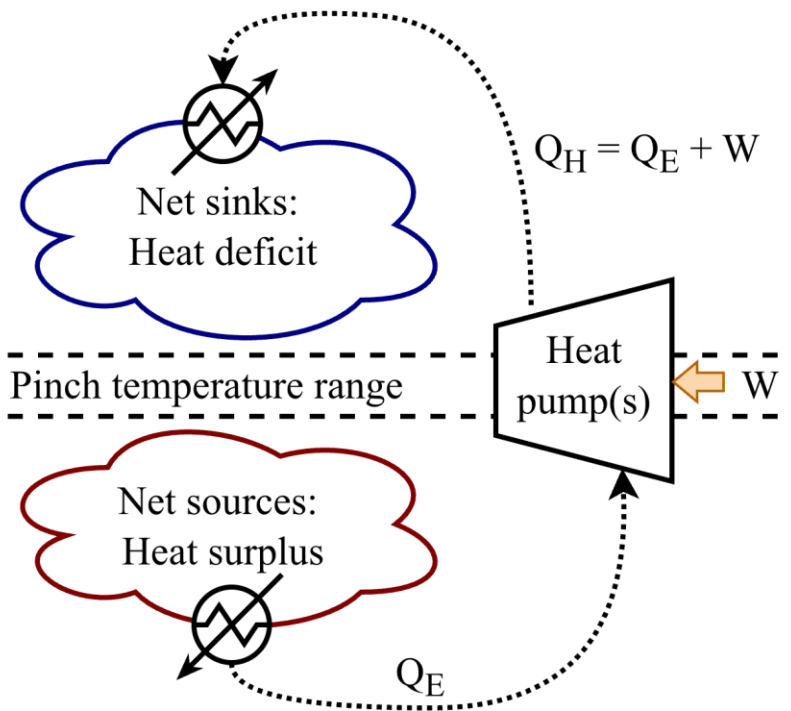

A Pinch Analysis Perspective

a) Abstract principle

b) Net load profiles with heat pumping

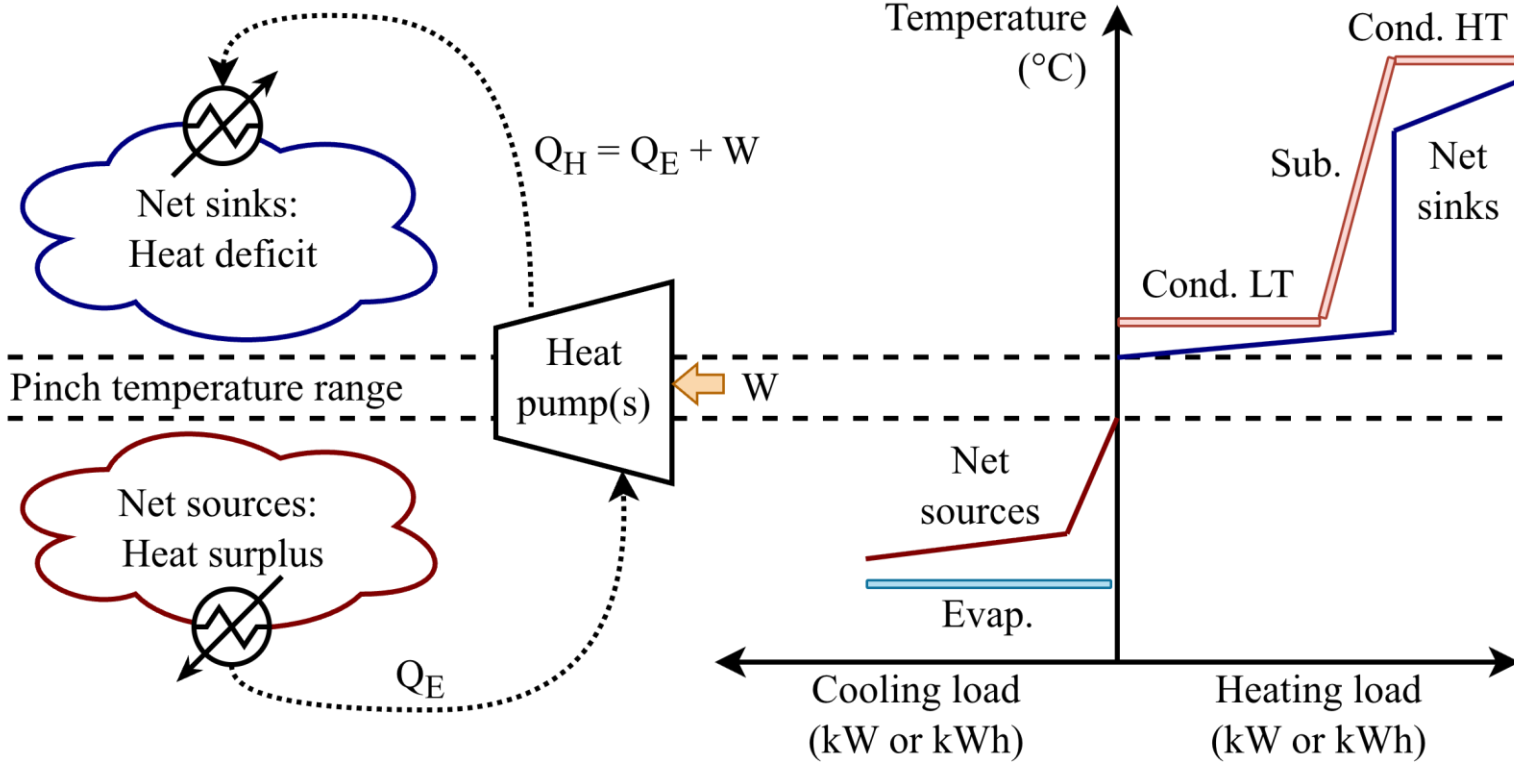

A Pinch Analysis Perspective

a) Abstract principle

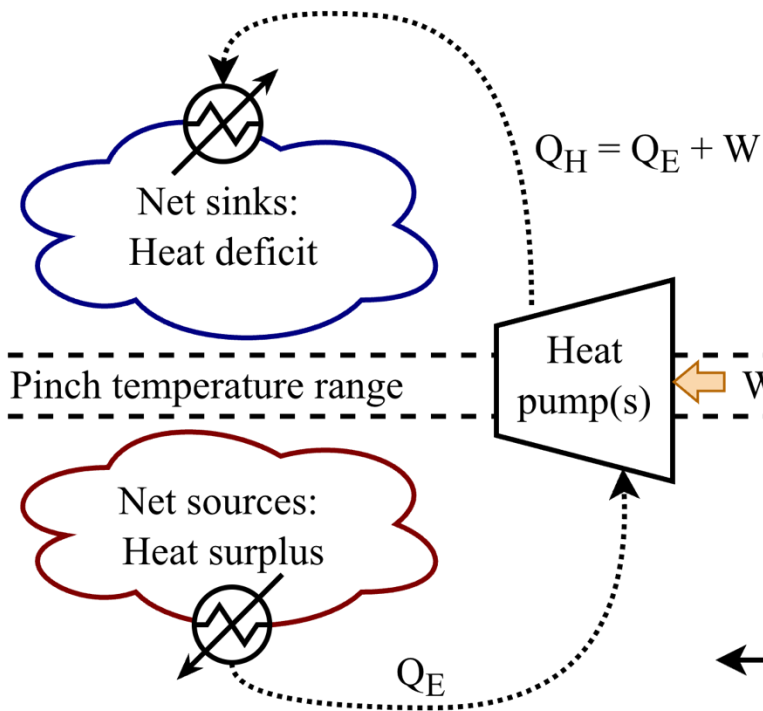

b) Net load profiles with heat pumping

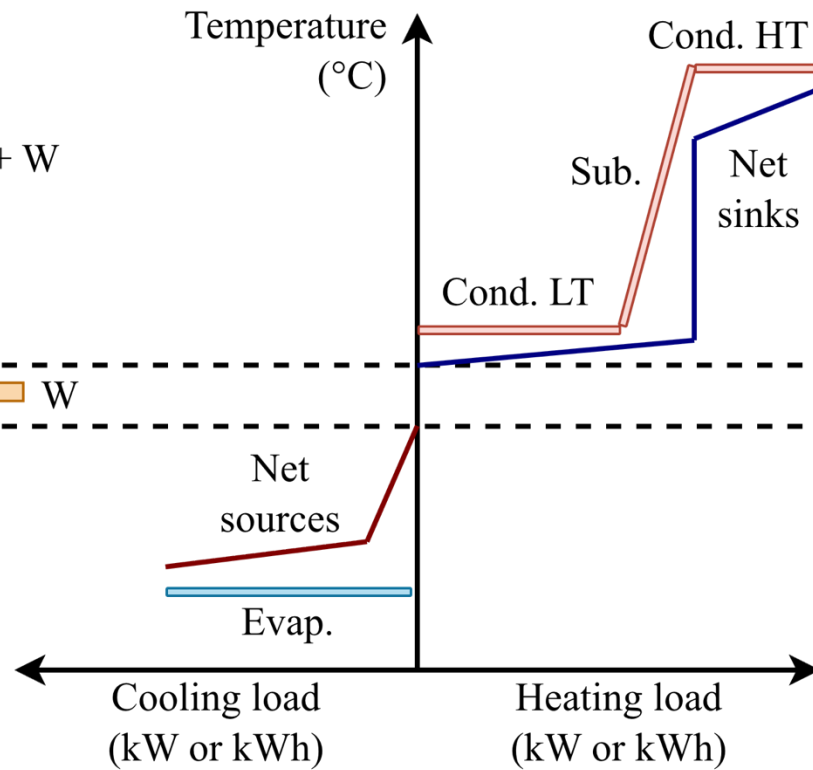

c) Heat pump system architecture

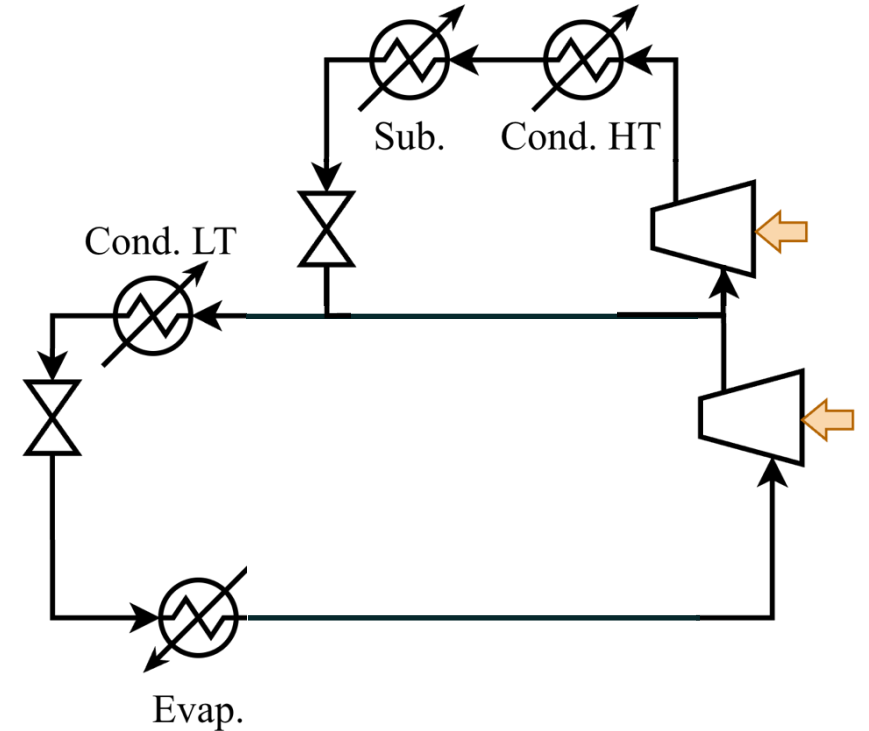

A Pinch Analysis Perspective

a) Abstract principle

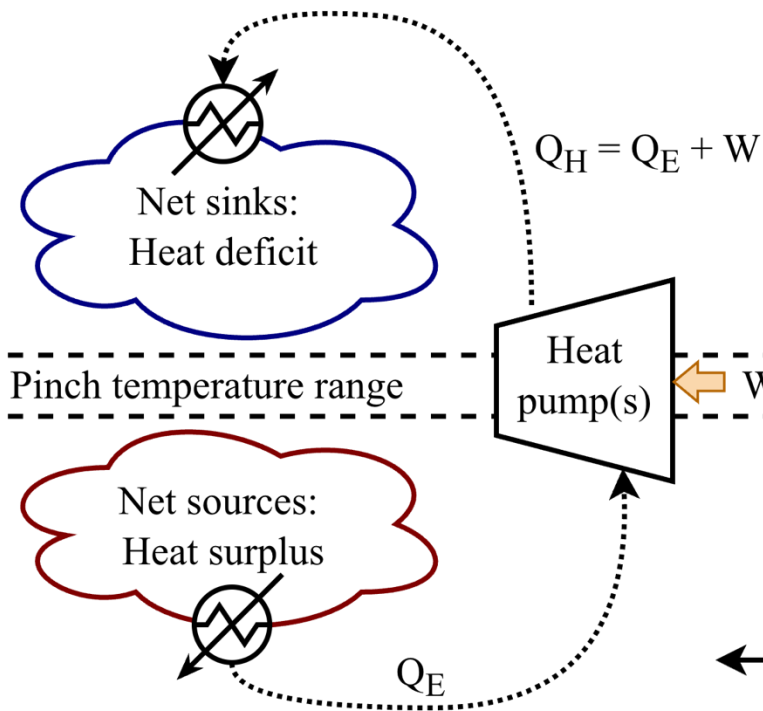

b) Net load profiles with heat pumping

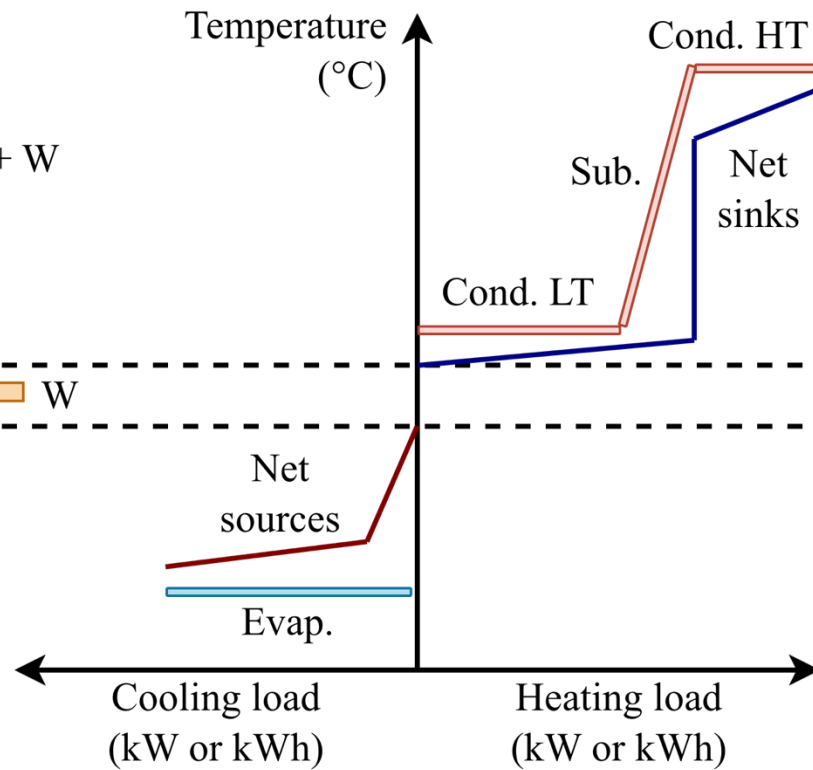

c) Heat pump system architecture

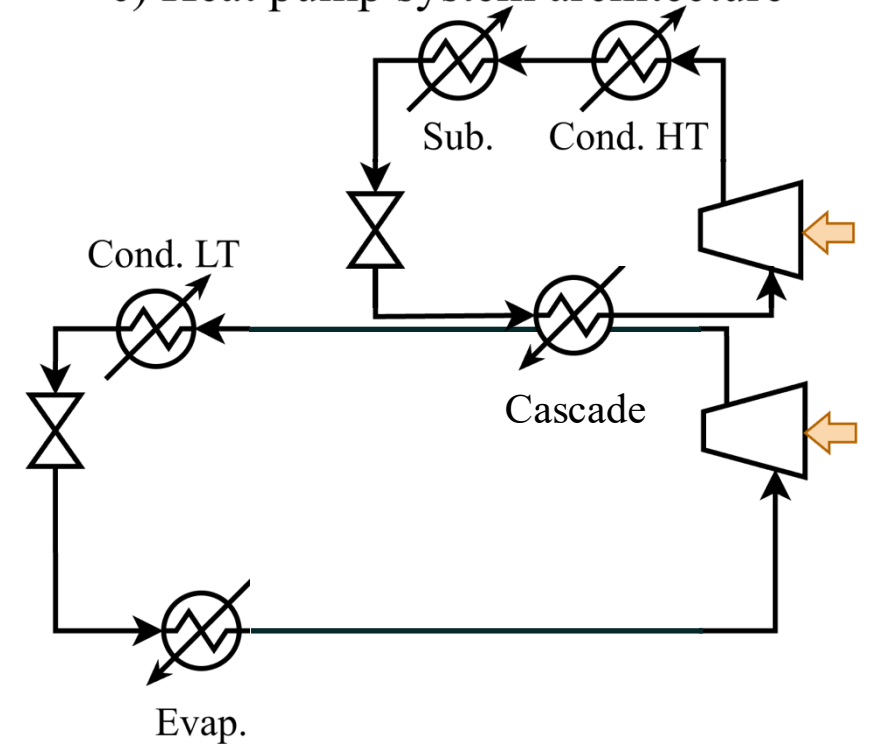

A Pinch Analysis Perspective

a) Abstract principle

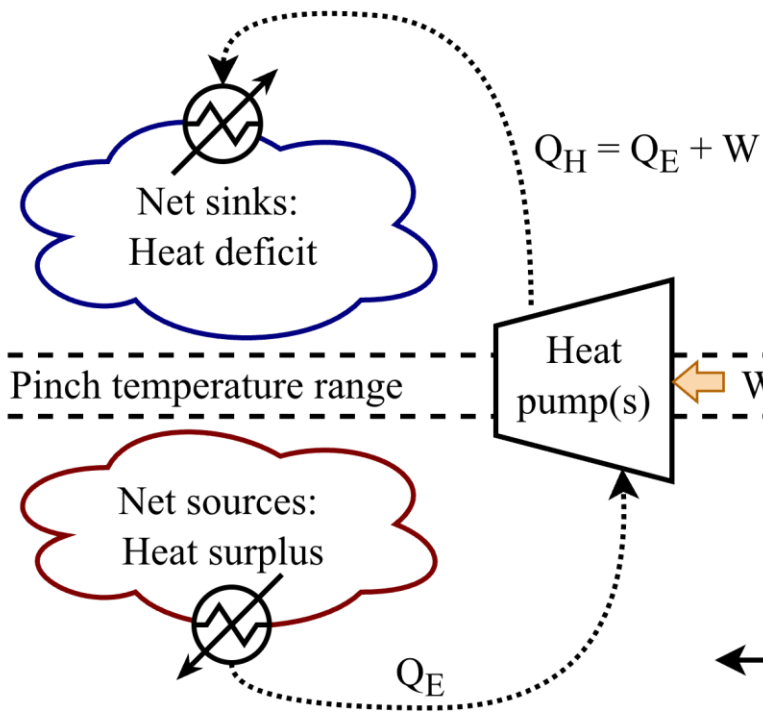

b) Net load profiles with heat pumping

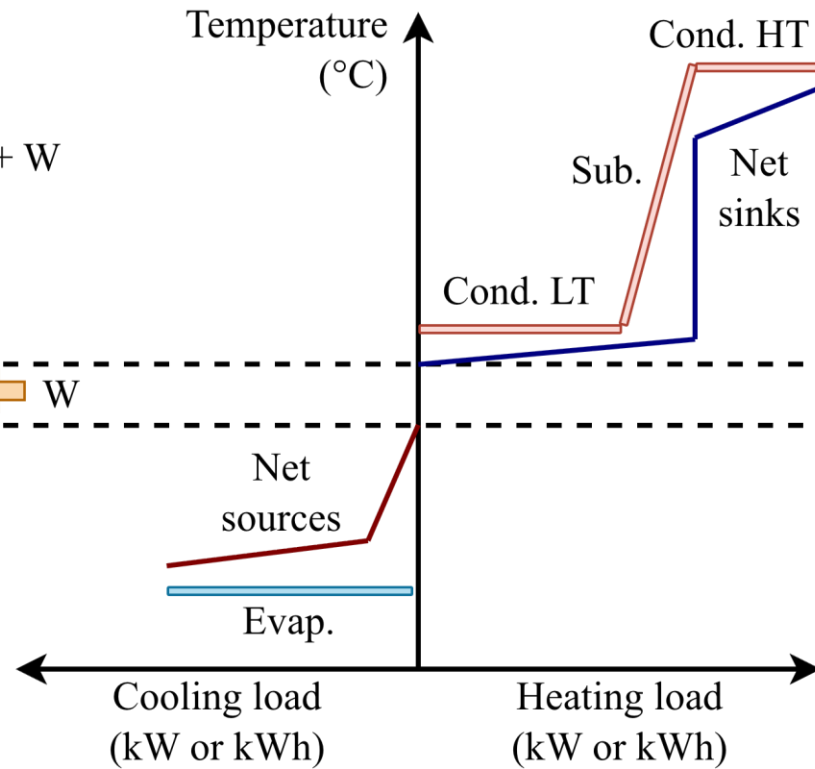

c) Heat pump system architecture

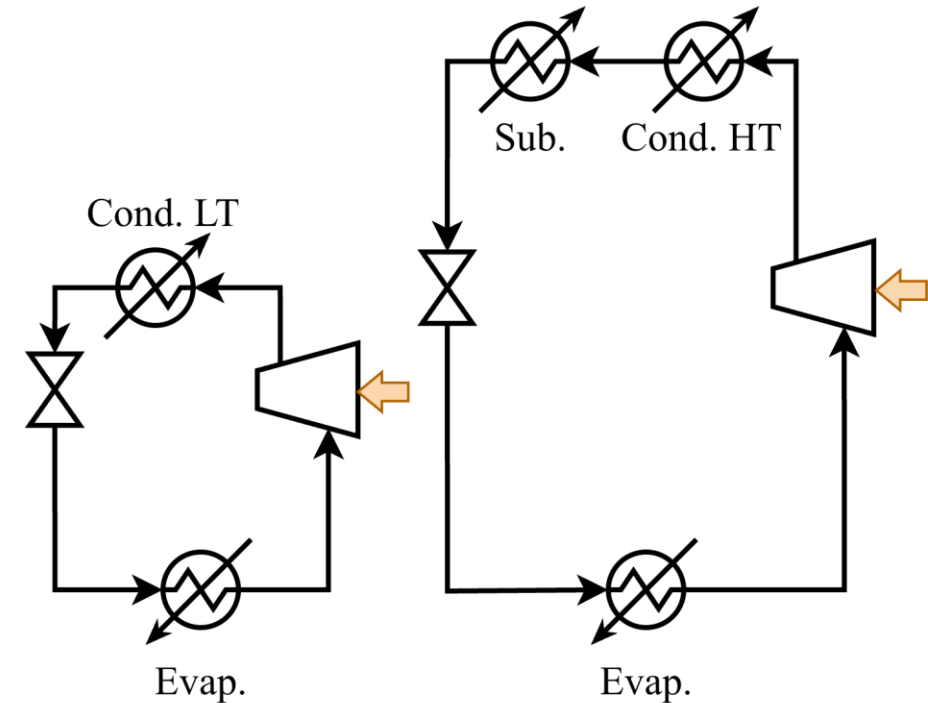

Heat Pump Integration & Design

Principles

1. Effective heat pumping upgrades heat across the pinch temperature.
2. Efficient heat pump minimises the mean temperature lift for a given heat load.
3. Efficient heat pumps minimise internal entropy generation.

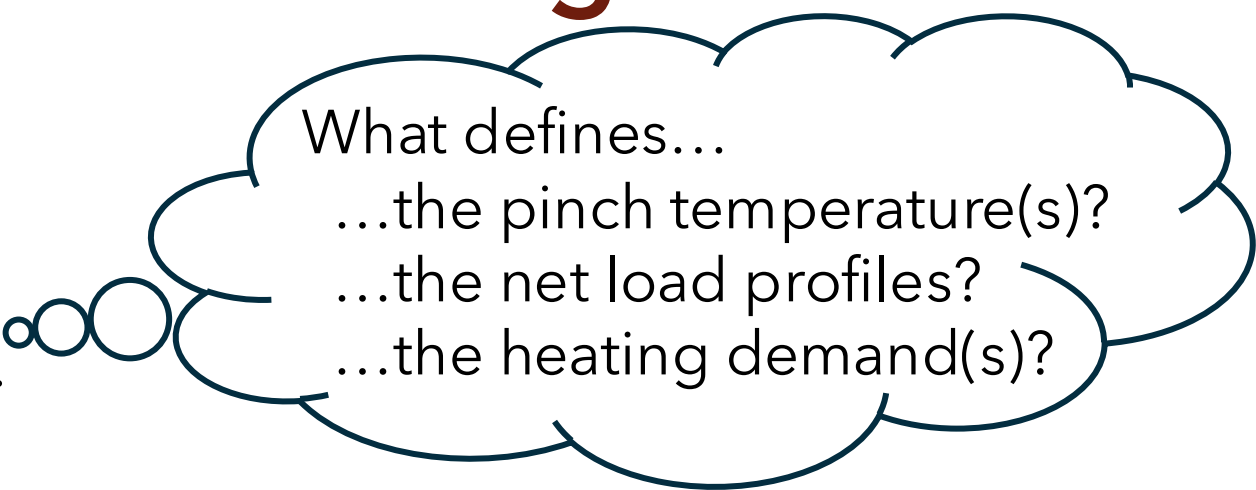
A thought bubble with a dark blue outline and three small circles at the tail, containing text.

What defines...
...the pinch temperature(s)?
...the net load profiles?
...the heating demand(s)?

Software Tool: Open Pinch Python

- The user defines the stream data via an Excel template or JSON format
- Open Pinch applies many pinch algorithms, especially the problem table and utility targeting
- Heat pump targeting options:
 - Process or utility integration
 - Carnot or CoolProp heat pump simulation (refrigerants, IHX)
 - Rankine or Brayton



```
HEN_problem.py X
classes > HEN_problem.py > ...
KeeganHAhuora, 4 months ago | 2 authors (KeeganHAhuora and one other)
''' You, 19 months ago - New HEN problem class as a gateway.
1  __author__ = 'Keegan Hall and Tim Walmstey'
2  __credits__ = ['tbc']
3  '''
4  '''
5  from gekko import GEKKO
6  import numpy as np
7  import pandas as pd
8  from pathlib import Path
9
10 from .stage_wise_model import StageWiseModel
11 from .grid_diagram import Grid_Diagram
12 from .pinch_decomp_model import PinchDecompModel
13 # solver settings and import should be here
KeeganHAhuora, 4 months ago | 2 authors (KeeganHAhuora and one other)
14 class HeatExchangerNetworkProblem:
15     def __init__(self,
16                 name='', # name of case and cut num
17                 version='', # version number on Git
18                 framework='dQ/dA', # specifies what
19                 remote_solve=True, # specifies whet
20                 solver=1,
21                 stages=2, # specifies how many stag
22                 dTmin=0.1, # specifies minimum appr
23                 import_file='', # specifies case to
24                 min_dqda=0, # specifies the minimum
25                 z_restriction=None, # specifies wet
26                 minimisation_goal='hot utility', #
27                 non_isothermal_model=False, # speci
28                 integers = True, # specifies wether
29                 init_variable_vals=None, # solved in
30                 integer_cut_solutions=None, # empty
31                 tol = 1e-6,
32                 pinch_loc = None): # location of mo
33     '''
34     Constructs arguments dictionary that conta
35     User provides the model details via strings
36     '''
37     self.name = name
38     self.framework = framework
39     self.remote_solve = remote_solve
40     self.solver = solver
41     self.stages = stages
42     self.dTmin = dTmin
43     self.import_file = import file
```



Chocolate Factory: Site-wide View

	System COP
<i>One heat pump</i>	
R600	2.88
R601A	3.17
R601	3.15
Water	2.28
<i>Two heat pumps</i>	
R600 & Ammonia	2.17
R601A & Ammonia	2.52
R601 & Ammonia	2.67
Water & Ammonia	3.07

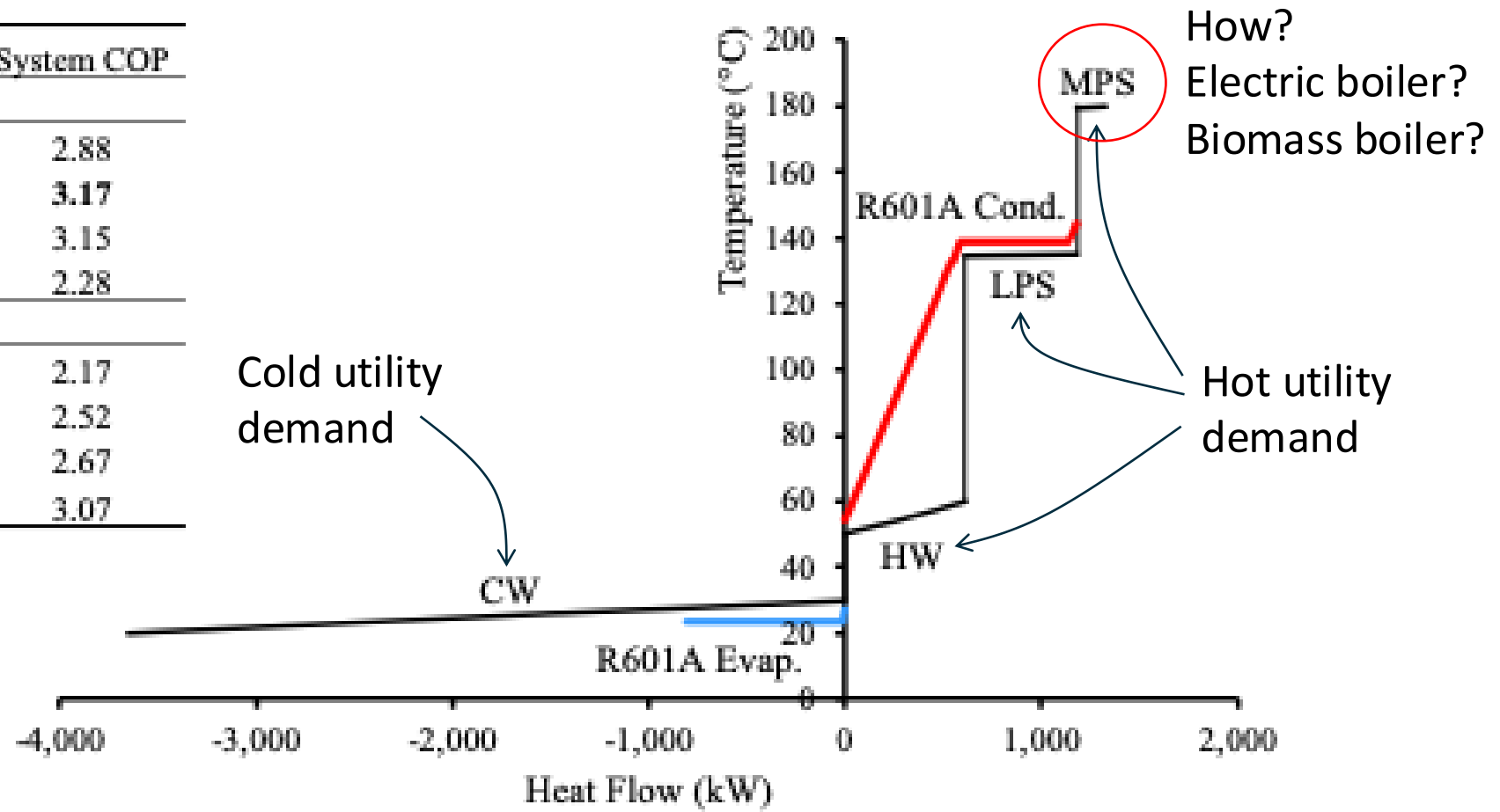

Dairy Factory: Site-wide View

	System COP
<i>One heat pump</i>	
R600	3.03
R601A	3.09
R601	3.01
Water	3.27
<i>Two heat pumps</i>	
R600 & Ammonia	3.56
R601A & Ammonia	3.40
R601 & Ammonia	3.68
Water & Ammonia	3.38

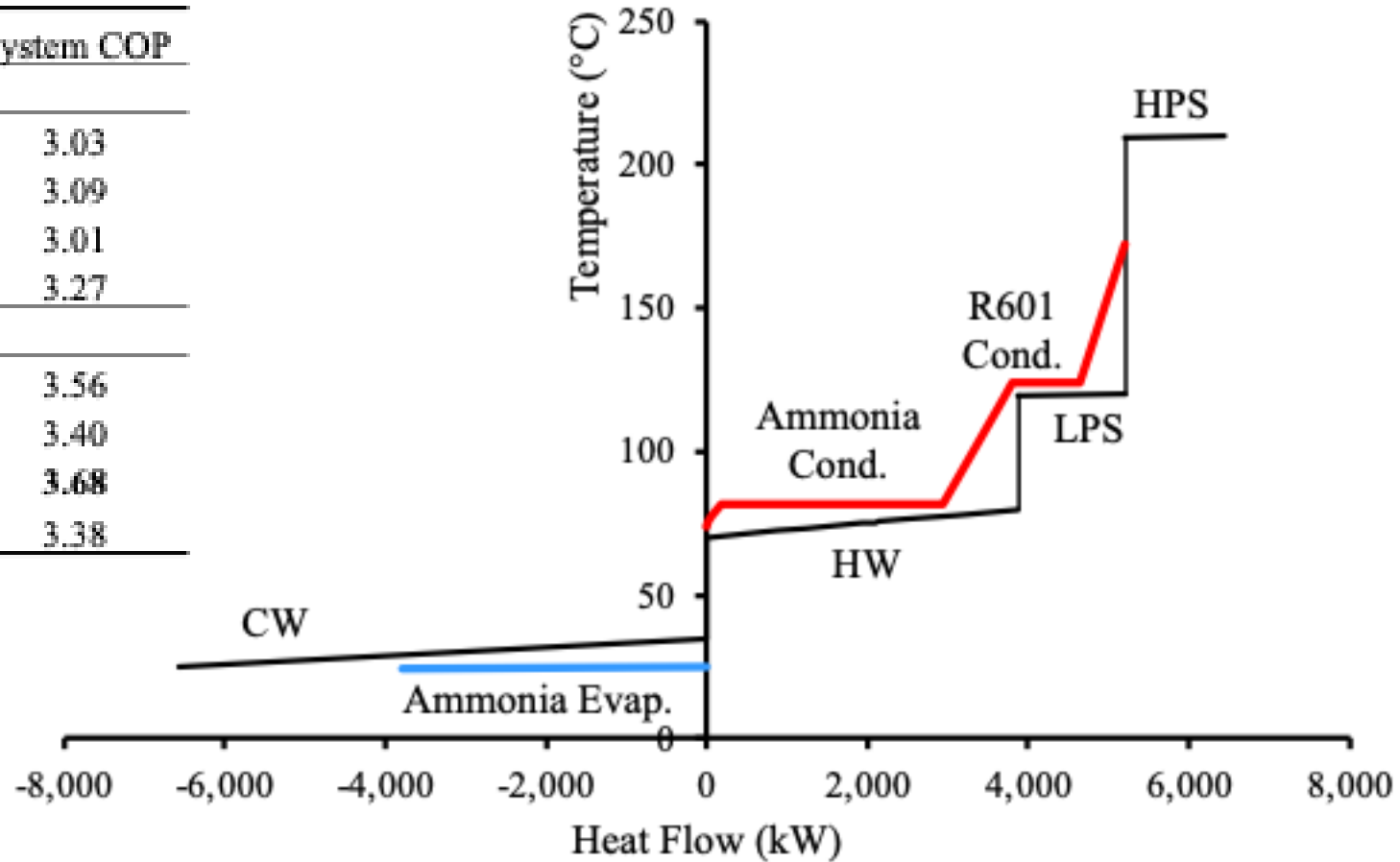

Meat Processing Factory

Rendering process

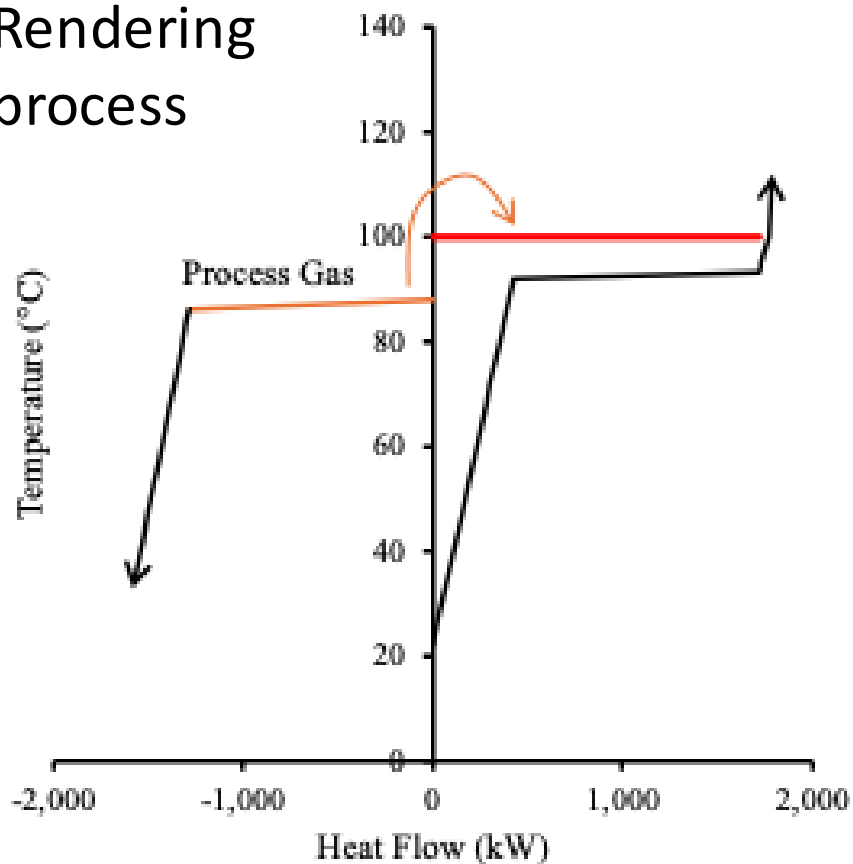

Site-wide utility generation

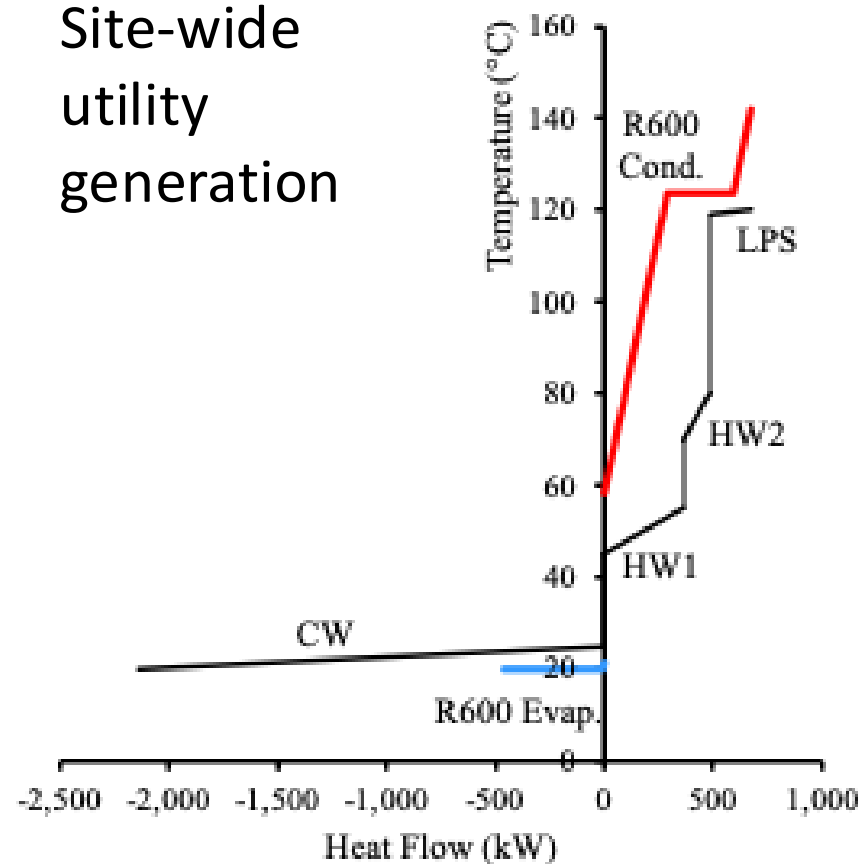

Heat Pump Integration & Design

Principles

1. Effective heat pumping upgrades heat across the pinch temperature.
2. Efficient heat pump minimises the mean temperature lift for a given heat load.
3. Efficient heat pumps minimise internal entropy generation.

Patterns

1. Direct process gas compression
2. Direct process heat supply
3. Localised hot water/steam loops
4. General site utility supply

Pattern	Minimum stream data requirement for analysis	Net load profile
1. Direct process gas compression	Process stream temperatures and duties (including heat recovery)	Process grand composite curve (detailed)
2. Direct process heat supply	Process stream temperatures and duties currently supplied by utility	Process grand composite curve (simplified)
3. Localised hot water/steam loops	Local stream temperatures and duties currently supplied by utility	Utility grand composite curve
4. General site utility supply	Site utility loads and temperatures	Site utility grand composite curve

Pattern	ΔT Lift	COP	Complexity	Heat Pump Investment Cost	Power Investment Cost
1. Direct process gas compression	\$	\$	\$\$\$\$	\$\$\$\$	\$
2. Direct process heat supply	\$\$	\$\$	\$\$\$	\$\$\$	\$\$
3. Localised hot water/steam loops	\$\$\$	\$\$\$	\$\$	\$\$	\$\$\$
4. General site utility supply	\$\$\$\$	\$\$\$\$	\$	\$	\$\$\$\$

Electricity Supply Upgrade

Data based on 83 site surveys in Waikato region, New Zealand.
EECA Waikato region – Renewable Energy Transition Accelerator report, 2024.

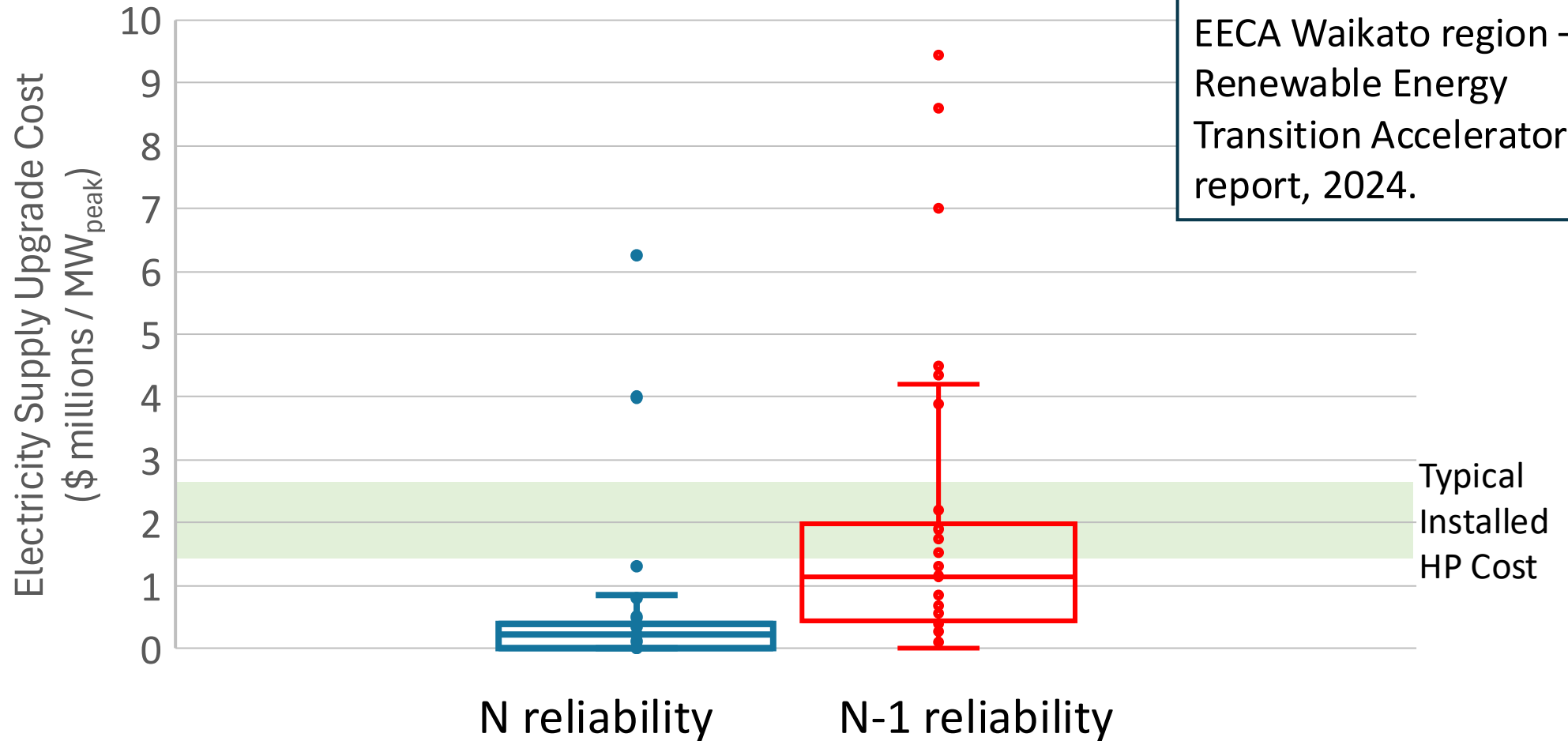

Conclusions

- Heat pumps integration requires advanced pinch analysis to ensure solutions are both effective and efficient for an industrial site.
- OpenPinch Python is an open-source tool to support engineers in conducting advanced pinch analyses
- Common patterns can guide engineers in deciding the appropriate type of analysis and positioning of heat pumps for a site.

Get in contact, follow our journey, and collaborate.

For more information, visit our website or email:
tim.walmsley@waikato.ac.nz

Follow us on
LinkedIn @Ahuora

