

# Demonstration of synchronized, galvanically isolated measurement devices

## Graduate



Thomas Rath

**Introduction:** Synchronization of measurements is important in many electrical engineering applications where parameters are measured using separate devices or channels.

For example, accurate time bases are needed for measurement of phase delay in RF systems and voltage measurements across transformer terminals. In high-voltage systems, galvanic isolation is required for safety and functionality.

Vector network analyzers (VNAs) are a typical example of devices with two channels that must remain synchronized to achieve precise phase measurements.

This thesis develops a data communication system for one base unit and two measurement channels, focusing on the communication protocol and absolute time synchronization.

**Approach:** Synchronizing a device to the received signal is challenging because the signal delay through the fiber-optic cable from the base to the channel cannot be compensated, as it is unknown.

A measurement of the phase shift between the base and measurement channel can be achieved using a DDMTD phase detector at the base. Measuring the total time offset requires communication between the base and measurement channel. By exchanging packets with timestamps between the units, the time offset can be calculated. This allows for the determination of the total time offset and the phase shift between the unit's clocks.

**Conclusion:** Many of the concepts explored in this thesis were successfully implemented. However, further efforts are necessary to address the remaining challenges and fully realize the proposed system's potential.

Measurement of clock jitter  
Own presentation

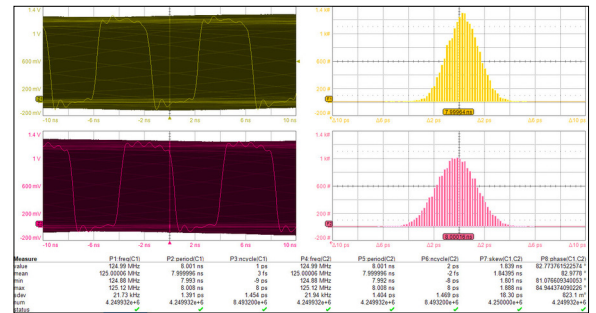

Picture of realized prototype  
Own presentation

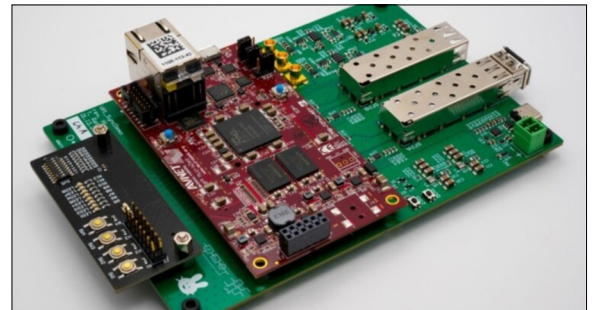

Block diagram: isolated Vector-Network-Analyzer (VNA) concept  
Own presentation

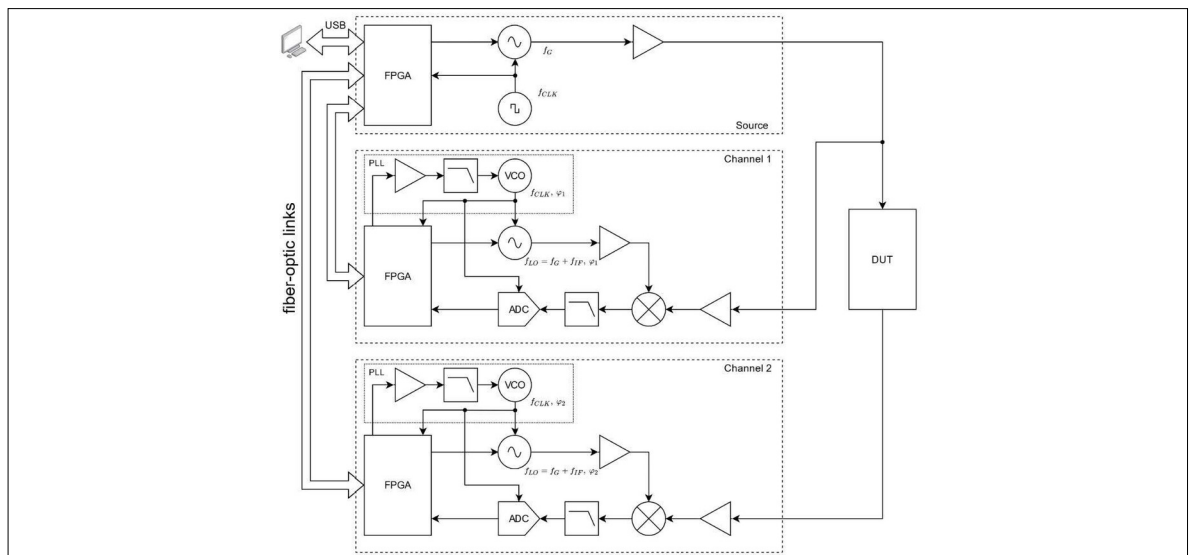

Advisor  
Prof. Guido Piai

Co-Examiner  
Prof. Laszlo Arato

Subject Area  
Electrical Engineering

Project Partner  
OMICRON electronics  
GmbH, Klaus,  
Österreich